

Installation/Operating Instructions

220V Premier Electric Projection Screen by Draper

These Installation/Operating Instructions are available in the official language of the country where you purchase the product. Please contact your distributor to request a copy.

Vous pourriez demander les instructions d'installation et d'opération traduites dans la langue officielle du pays où vous achetez le produit. Veuillez demander à votre distributeur.

Die Gebrauchsanweisung für Installation und Konstruktion sind in der offiziellen Sprache des Landes, indem Sie das Produkt gekauft haben, vorhanden. Fragen Sie die jeweilige Verkaufs-Abteilung.

Caution

- 1 Read instructions through completely before proceeding.
- 2 Follow instructions carefully. Installation contrary to instructions invalidates warranty.
- 3 Screen should be accessible for complete removal should fabric become damaged or should other service be required.
- 4 Screen should be installed level (using a carpenter's level).
- 5 Nothing should be fastened to screen dowel or viewing surface.
- 6 Operating switch(es) packed separately in screen carton. Do not discard with packing material.
- 7 Screen operates on 220V AC, 50 Hz., 1 ph. current.

NOTE: Screen has been thoroughly inspected and tested at factory and found to be operating properly prior to shipment.

These instructions are meant as a guide only. They do not imply any responsibility on the part of Draper, Inc. for improper installation or faulty workmanship at the jobsite.

Hanging Screen

General: When locating viewing surface and checking clearance for screen's operation, remember surface is centered in case. Handle case carefully to protect finish. Regardless of mounting method, screen should be positively and securely supported so vibration or even abusive pulling on the viewing surface will not cause case to work loose or fall. Installer must insure that fasteners used are of adequate strength and suitable for mounting surface.

Suspended Installation:

Suspend screens from holes in endcaps as shown. S-hooks, chains (or cable) and turnbuckles should be provided by installer. "S" hooks should go through the front holes on the endcaps (see drawing on page 2), and both ends of the "S" hooks should be crimped for additional safety. Chains should be attached to beams or other structural members. Turnbuckles should be adjusted so screen hangs level.

Wall Installation:

Mount screen through holes in back of endcaps as shown. Installer should furnish screws, toggle bolts, molly bolts, nylon or lead anchors as required.

Recessed Installation:

Recess should permit access for removal of screen if necessary. Screen may be mounted as in suspended or wall installation. Optional Ceiling Opening Trim Kit also available; see diagram on page 2 and separate instruction sheet (included with Ceiling Opening Trim Kit).

Electrical Connections

Screen operates on 220V AC, 50 Hz., 1 ph. current. Junction box located inside left endcap and cover plate is secured to endcap with two screws. Junction box contains terminal strip, per wiring diagram on reverse. Screen shipped with internal wiring complete and control switch(es) fully boxed. Wire connecting screen to switch(es) and switch(es) to power supply should be furnished by installer. Connections should be made in accordance with wiring diagram; wiring should comply with national and local electrical codes.

All operating switches should be "Off" before power is connected.

DRAPER

411 S. Pearl St., Spiceland, IN 47385 USA ■ 765-987-7999

www.draperinc.com ■ fax 765-987-1689

Copyright © 2007 Draper Inc. Form Premier220v_Inst07 Printed in U.S.A.

Operation

CAUTION—Important Instructions—The shipping support brackets must be removed from each end of dowel during initial operation before screen is operated in UP direction. After screen is installed, run viewing surface DOWN to access screws that hold brackets to dowel. Loosen hex head screw, remove bracket and retighten screw at each end of dowel. See page two for diagram of bracket. Cycle viewing surface down and up several times to confirm satisfactory operation. If viewing surface does not operate properly, turn power off and check electrical connections.

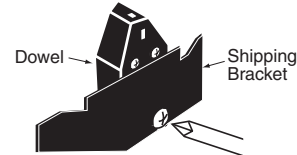

220V Single Station Control—3-position up-off-down switch permits operation to be stopped at any point. Factory adjusted limit switches automatically stop screen when fully down or fully up.

220V Multiple Station Control (Not CE approved)—Switches are similar in appearance to 220V Single Station Control. Screen stops when switch is released and may be restarted in either direction. Factory adjusted limit switches stop screen automatically when fully up or fully down.

24V Control—Three-button up-stop-down switch(es) stop at any point desired, operate in any sequence. Factory adjusted limit switches automatically stop screen when fully up or fully down. Installer should incorporate all-pole disconnect in the fixed wiring.

Key Operated Switching (Not CE approved)—Two kinds of key-operated switches are optionally available with this unit. ① The key-operated power supply switch controls power to the screen and switches. When it is "off", the switches will not operate screen. Key may be removed from the switch in either "on" or "off" position. ② A three-position key switch permits the screen to be operated directly by key. In this case, the operator must always have a key.

RS232/Ethernet—Serial communication and network communication optionally available with wall switches, RF or IR remote.

Adjustments

Screen has been factory set and should not normally require further adjustment. However, if you desire to change the "up" and "down" stopping positions, proceed as follows:

CAUTION: Be sure all switches are in "off" position before adjusting limit switches. Always be prepared to shut screen off manually when new adjustment is being tested. Screen may be severely damaged if viewing surface is allowed to run too far up or too far down.

Adjusting "fully up" position—"Up" stopping position may be adjusted by turning the yellow limit switch adjustment socket. The yellow socket is located on left end of screen roller and is accessible to a screwdriver/Allen wrench (4mm or 5/32"). Turning the socket counterclockwise will allow the viewing surface to retract farther into the case. Turning it clockwise will cause the surface to stop farther out of the case. One full revolution of the socket will alter the stopping position of the viewing surface by approximately 3.8 cm.

Adjusting "fully down" position—"Down" stopping position may be adjusted by turning the white limit switch adjustment socket. The white socket is located on the left end of screen roller and is accessible to a screwdriver/Allen wrench (4mm or 5/32"). Turning socket counterclockwise will allow viewing surface to run farther down. Turning clockwise will shorten viewing surface, causing it to stop in a less extended position. At no time should viewing surface be unrolled enough to expose any part of screen roller.

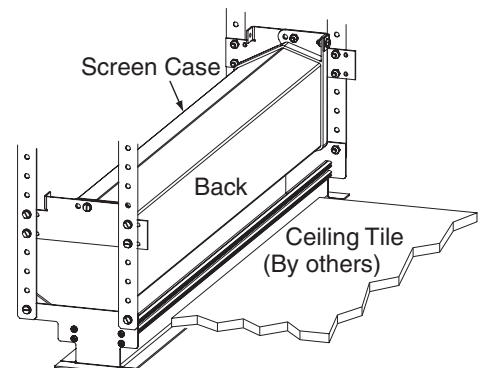

Please Note: Instructions for adjusting Draper's Tab-Tension System are on page 2.

Tab-Tension Adjustment Procedure

Draper's Tab-Tensioning System is factory-set, and under normal circumstances will not require field adjustment. If, however, you notice wrinkles, waves or other indications that the tensioning cables need to be adjusted, follow the procedure below.

- ① Determine which side requires adjustment.
- ② Secure dowel with one hand.

Caution: Do not touch or bend surface.

- ③ Using Phillips-head screwdriver, depress spring-loaded adjustment screw and slowly turn clockwise to tighten tension, or counterclockwise to loosen tension. The screw adjusts in 1/4 turn increments. Adjust only **one increment (1/4 turn) at a time.**

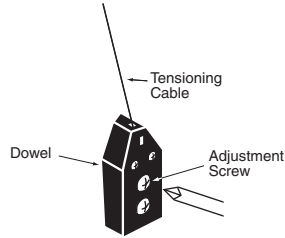

- ④ If problem is not corrected, leave screen in position for 24 hours to allow surface material to stretch into position.
- ⑤ If problem still is not corrected, repeat steps 2 and 3.

Case Dimensions

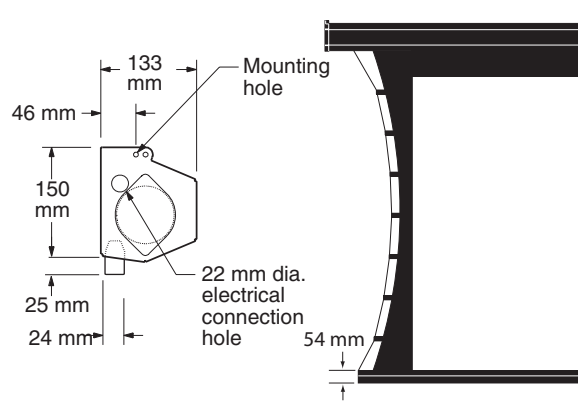

220v Wiring Diagrams

Single Station Control
CE Approved

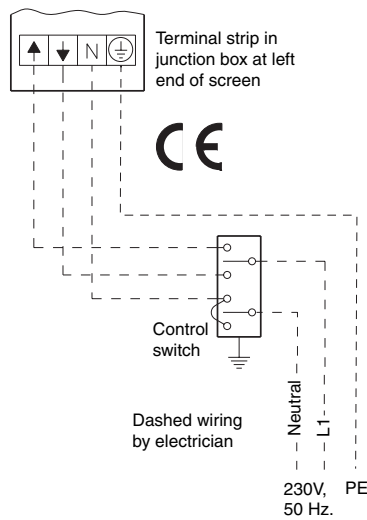

Multiple Station Control
Not CE Approved

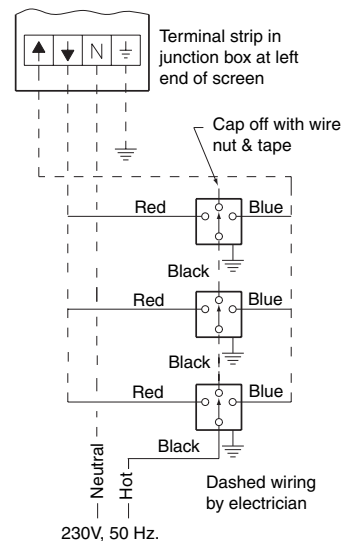

Installation with Ceiling Trim Kit

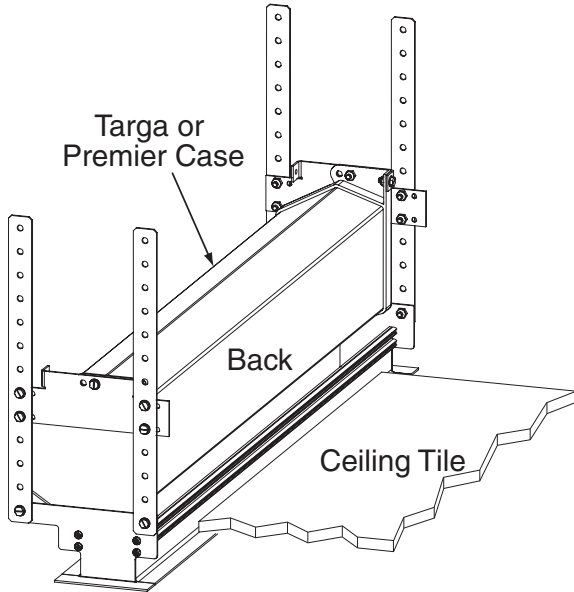

Other Types of Installation

Suspended

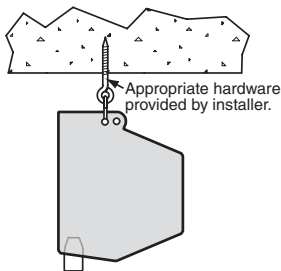

Wall

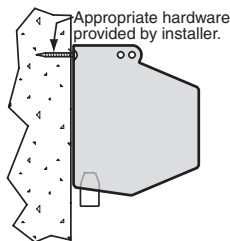

Low Voltage & Wireless Control

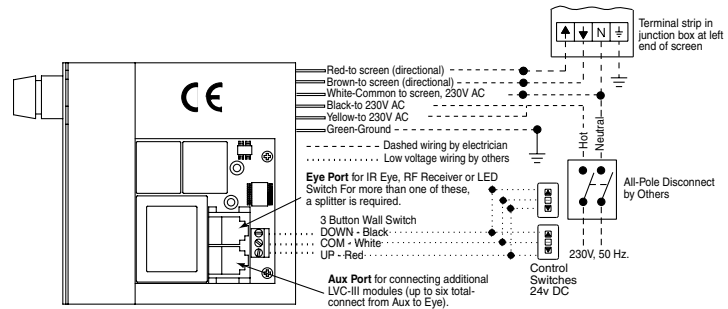

MC1

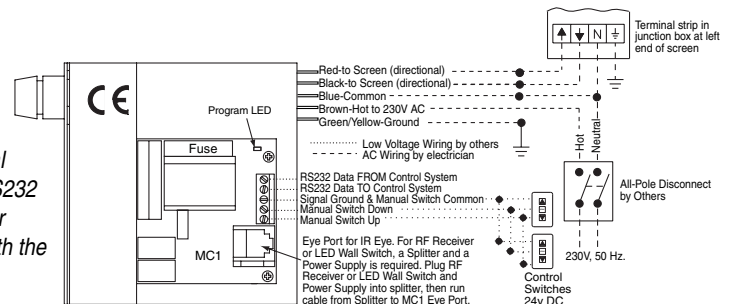

See separate Serial Communication-RS232 Instruction sheet for enabling RS232 with the MC1.

If you encounter any difficulties installing or servicing your Premier screen, call your dealer or Draper, Inc. Spiceland, Indiana, U.S.A., 765/987-7999 or fax 765-987-1689.