

Installation/Operating Instructions

220V Targa Electric Projection Screen by Draper

These Installation/Operating Instructions are available in the official language of the country where you purchase the product. Please contact your distributor to request a copy.

Vous pourriez demander les instructions d'installation et d'opération traduites dans la langue officielle du pays où vous achetez le produit. Veuillez demander à votre distributeur.

Die Gebrauchsanweisung für Installation und Konstruktion sind in der offiziellen Sprache des Landes, indem Sie das Produkt gekauft haben, vorhanden. Fragen Sie die jeweilige Verkaufs-Abteilung.

Caution

- 1 Read instructions through completely before proceeding.
- 2 Follow instructions carefully. Installation contrary to instructions invalidates warranty.
- 3 Screen should be accessible for complete removal should fabric become damaged or should other service be required.
- 4 Screen should be installed level (using a carpenter's level).
- 5 Nothing should be fastened to screen dowel or viewing surface.
- 6 Operating switch(es) packed separately in screen carton. Do not discard with packing material.
- 7 Screen operates on 220V AC, 50 Hz., 1 ph. current.

NOTE: Screen has been thoroughly inspected and tested at factory and found to be operating properly prior to shipment.

Hanging Screen

General: When locating viewing surface and checking clearance for screen's operation, remember surface is centered in case. Handle case carefully to protect its finish.

Regardless of mounting method, screen should be positively and securely supported so that vibration or even abusive pulling on the viewing surface will not cause case to work loose or fall. Installer must insure that fasteners used are of adequate strength and suitable for the mounting surface chosen.

Suspended Installation:

Suspend screens from holes in endcaps as shown. S-hooks, chains (or cable) and turnbuckles should be provided by installer. "S" hooks should go through the front holes on the endcaps (see drawing on page 2), and both ends of the "S" hooks should be crimped for additional safety. Chains should be attached to beams or other structural members. Turnbuckles should be adjusted so screen hangs level.

Wall Installation:

Mount screen through holes in back of endcaps as shown. Installer should furnish screws, toggle bolts, molly bolts, nylon or lead anchors as required.

Wall Installation with 15 cm Extension Brackets:

Mount the brackets (not included with screen—see diagram below right) using hardware recommended for "Wall Installation" (above). Then, suspend the screen from the front holes with "S" hooks (as in "Suspended"). For added safety, crimp both ends of the "S" hooks so the screen cannot come off. For a more rigid installation, mount the screen from the back holes to the front of the bracket by using the screws and nuts provided with the brackets.

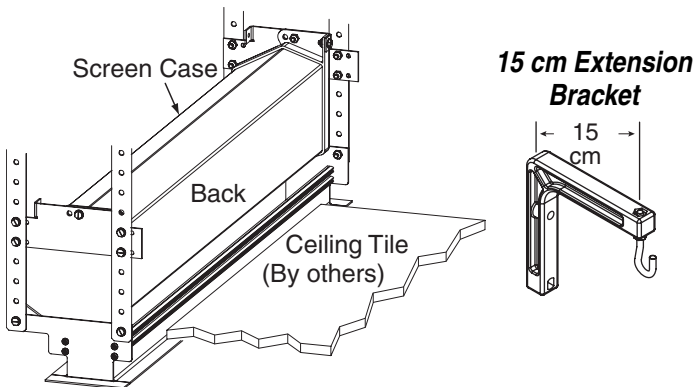

Recessed Installation:

Recess should permit access for removal of screen if necessary. Screen may be mounted as in suspended or wall installation. Optional Ceiling Opening Trim Kit available; see diagrams below and on page 2, and separate instruction sheet (included with Ceiling Opening Trim Kit).

Electrical Connections

Screen operates on 220V AC, 50 Hz., 1 ph. current.

Junction box is located inside left endcap and cover plate is secured to endcap with two screws. Junction box contains terminal strip, per wiring diagram on reverse.

Screen is shipped with internal wiring complete and control switch(es) fully boxed. Wire connecting screen to switch(es) and switch(es) to power supply should be furnished by installer. Connections should be made in accordance with wiring diagram supplied, and wiring should comply with national and local electrical codes.

All operating switches should be "Off" before power is connected.

Operation

Before operating screen remove tape securing fabric and dowel to roller. If viewing surface hangs out of case 22 or 23 mm, tape has probably been broken by rough handling in shipment, allowing surface to "unwrap" one turn about the roller. Manually wrap fabric back around roller without turning the roller itself.

Note: Drive unit contains a thermal overload protector. Operation as frequently as six cycles per hour may trip the protector. If tripped, the protector should reset automatically within a few minutes.

220V AC Single Station Control—3-position up-off-down switch permits operation to be stopped at any point. Factory adjusted limit switches automatically stop screen when fully down or fully up.

220V AC Multiple Station Control (Not CE approved)—Switches are similar in appearance to 220V Single Station Control. Screen stops when switch is released and may be restarted in either direction. Factory adjusted limit switches stop screen automatically when fully up or fully down.

24V Control—Three-button up-stop-down switch(es) stop at any point desired, operate in any sequence. Factory adjusted limit switches automatically stop screen when fully up or fully down. Installer should incorporate an all-pole disconnect in the fixed wiring.

Key Operated Switching (Not CE approved)—Two kinds of key-operated switches are optionally available with this unit. ① The key-operated power supply switch controls power to the screen and switches. When it is "off", the switches will not operate screen. Key may be removed from the switch in either "on" or "off" position. ② A three-position key switch permits the screen to be operated directly by key. In this case, the screen's operator must always have a key.

RS232/Ethernet—Serial communication and network communication optionally available with wall switches, RF or IR remote.

Adjustments

Screen has been factory set and should not normally require further adjustment. However, if you desire to change the "up" and "down" stopping positions, proceed as follows:

CAUTION: Be sure all switches are in "off" position before adjusting limit switches. Always be prepared to shut screen off manually when new adjustment is being tested. Screen may be severely damaged if viewing surface is allowed to run too far up or too far down.

Adjusting "fully up" position — "Up" stopping position may be adjusted by turning the UP limit switch adjustment socket. The UP socket is located on left end of screen roller and is accessible to a screwdriver/Allen wrench (4mm or 5/32"). Turning the socket counterclockwise will allow the viewing surface to retract farther into the case. Turning it clockwise will cause surface to stop farther out of the case. One full revolution of socket will alter stopping position of viewing surface by approximately 4 cm.

Adjusting "fully down" position — "Down" stopping position may be adjusted by turning the DOWN limit switch adjustment socket. The DOWN socket is located on the left end of screen roller and is accessible to a screwdriver/Allen wrench (4mm or 5/32"). Turning the socket counterclockwise will allow the viewing surface to run farther down. Turning it clockwise will shorten viewing surface, causing it to stop in a less extended position. At no time should viewing surface be unrolled enough to expose any part of screen roller.

DRAPER®

411 S. Pearl St., Spiceland, IN 47385 USA ■ +1 765-987-799

www.draperinc.com ■ fax +1 765-987-1689

Copyright © 2009 Draper Inc. Form Targa220V_Inst09 Printed in U.S.A.

If you encounter any difficulties installing or servicing your Targa screen, call your dealer or Draper, Inc. Spiceland, Indiana, U.S.A., telephone (765) 987-7999 or fax (765) 987-1689.

Case Dimensions/Installation Diagrams

Wall Mounted

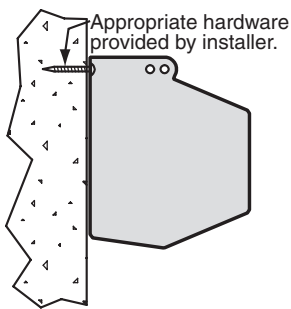

Suspended

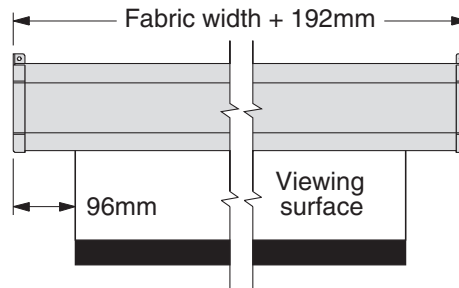
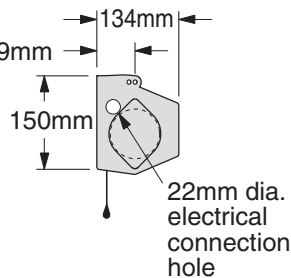
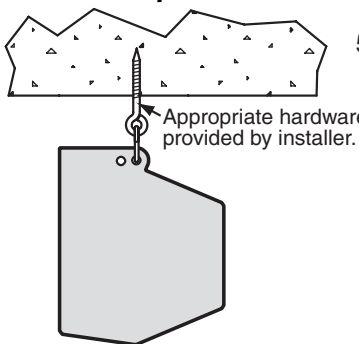

220V Wiring Diagrams

Methods of Installation

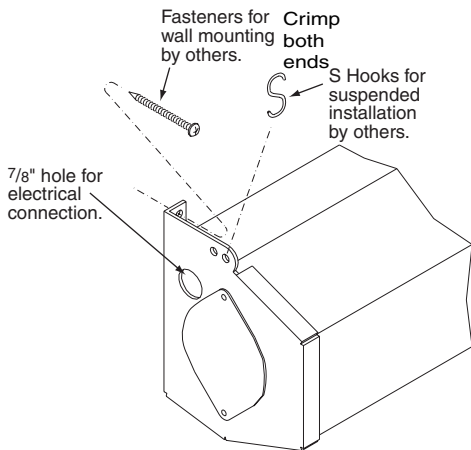

Single Station Control CE Approved

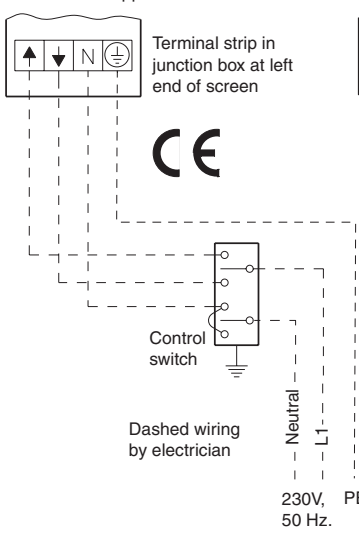

Multiple Station Control Not CE Approved

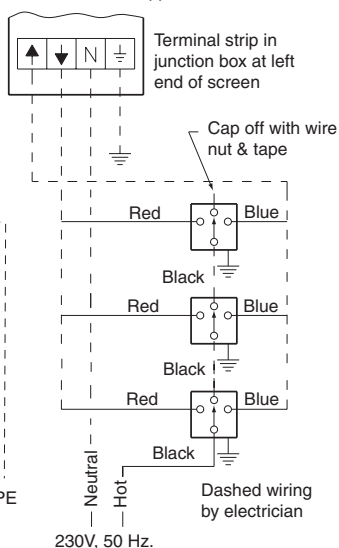

Optional Ceiling Opening Trim Kit (Dims-Side View)

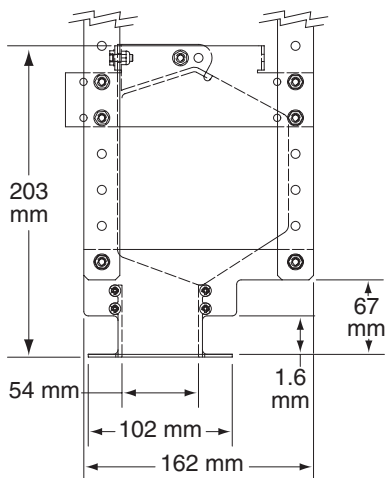

Low Voltage & Remote Control (LVC-III)

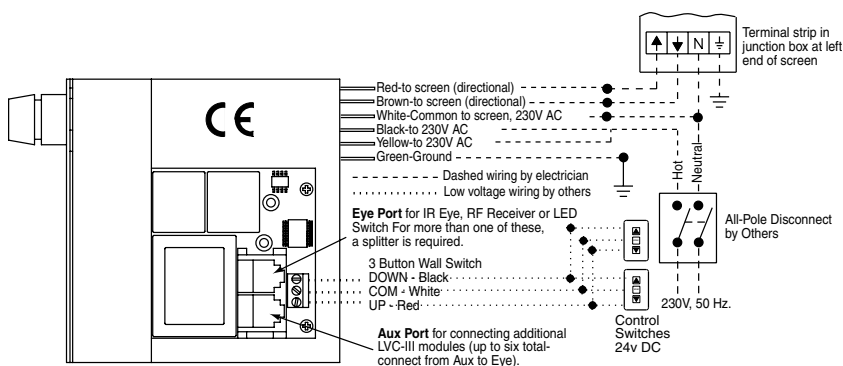

MC1

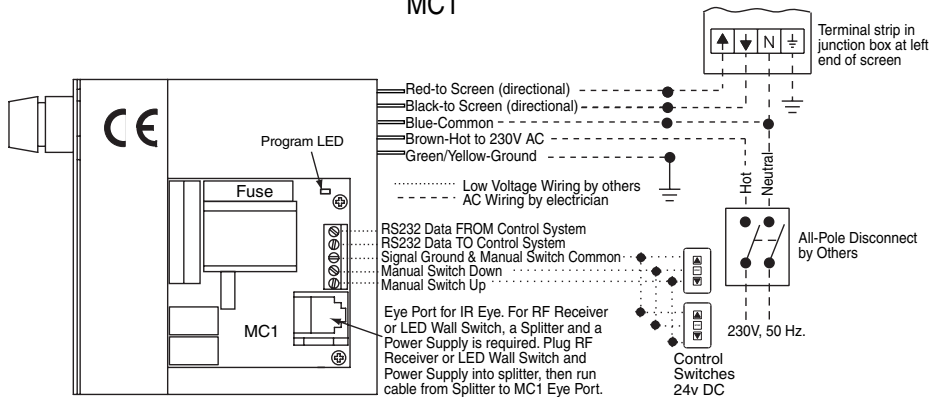

See separate Serial Communication-
RS232 Instruction sheet for enabling
RS232 with the MC1.